

2280 Hydrostatic Drive Windrower



TECHNICAL MANUAL 2280 Hydrostatic Drive Windrower

TM1179 (01APR83) English

TM1179 (01APR83)

LITHO IN U.S.A.
ENGLISH

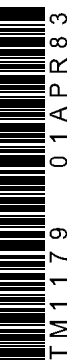

2280 HYDROSTATIC-DRIVE

WINDROWER

Technical Manual

TM-1179 (Apr-83)

CONTENTS

SECTION 10 - GENERAL

- Group 5 - Specifications
- Group 10 - Predelivery, Delivery, and After-Sale Service
- Group 15 - Tune-Up
- Group 20 - Lubrication
- Group 25 - Separation
- Group 30 - Special Tools

SECTION 20 - ENGINE

- Group 5 - General Information and Diagnosis
- Group 10 - Cylinder Head, Valves, Camshaft and Timing Gear Train
- Group 15 - Cylinder Block, Liners, Pistons, and Rods
- Group 20 - Crankshaft, Main Bearings, and Flywheel
- Group 25 - Lubrication System
- Group 30 - Cooling System
- Group 35 - Specifications, Torques, and Special Tools

SECTION 30 - FUEL SYSTEM

- Group 5 - Diagnosing Malfunctions
- Group 10 - Air Filtering System
- Group 15 - Fuel System
- Group 20 - Control Linkage
- Group 25 - Specifications, Torques, and Special Tools

SECTION 40 - ELECTRICAL SYSTEM

- Group 5 - Information and Diagrams
- Group 10 - Charging Circuit
- Group 15 - Starting Circuit
- Group 20 - Lighting and Miscellaneous Components
- Group 25 - Specifications, Torques, and Special Tools

SECTION 50 - POWER TRAIN

- Group 5 - General Information
- Group 10 - Main Drive Case and Drive Shaft
- Group 15 - Final Drive
- Group 20 - Platform Drives
- Group 25 - Specifications, Torque Values and Special Tools

SECTION 60 - STEERING AND BRAKES

- Group 5 - Steering
- Group 10 - Brakes
- Group 15 - Specifications

SECTION 70 - HYDRAULIC SYSTEM

- Group 5 - Diagnosing System Malfunctions
- Group 10 - General Information, Components and Tests
- Group 15 - Reservoir, Filter, and Oil Cooler
- Group 20 - Control Valves
- Group 25 - Hydraulic Cylinders
- Group 30 - Hydrostatic Transmission
- Group 35 - Specifications, Torques, and Special Tools

SECTION 80 - OPERATOR'S CAB

- Group 5 - Pressurizer System
- Group 10 - Air Conditioning System
- Group 15 - Seat
- Group 20 - Specifications, Torques, and Special Tools

All information, illustrations and specifications contained in this technical manual are based on the latest information available at the time of publication. The right is reserved to make changes at any time without notice.

Copyright © 1983
DEERE & COMPANY
Moline, Illinois
All rights reserved

New and revised information is identified by vertical lines in the margin of the pages.

INTRODUCTION

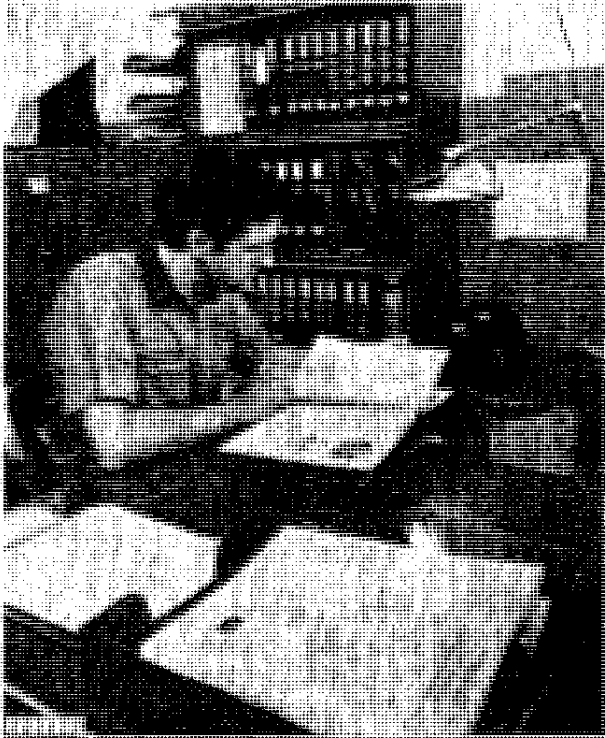

Use FOS Manuals for Reference

This technical manual is part of a twin concept of service:

- **FOS Manuals—for reference**
- **Technical Manuals—for actual service**

The two kinds of manuals work as a team to give you both the general background and technical details of shop service.

Fundamentals of Service (FOS) Manuals cover basic theory of operation, *fundamentals* of trouble shooting, *general* maintenance, and *basic* types of failures and their causes. FOS Manuals are for training new people and for reference by experienced technicians.

Technical Manuals are *concise* service guides for a *specific* machine. Technical Manuals are on-the-job guides containing only the vital information needed by an experienced technician.



When a service technician should refer to a FOS Manual for more information, a FOS symbol like the one at the left is used in the TM to identify the reference.



Use Technical Manuals for Actual Service

Some features of this technical manual.

- *Table of contents at front of manual*
- *Exploded views showing parts relationship*
- *Photos showing service techniques*
- *Specifications grouped for easy reference*

This technical manual was planned and written for you—a service technician. Keep it in a permanent binder in the shop where it is handy. Refer to it whenever in doubt about correct service procedures or specifications.

Using the technical manual as a guide will reduce error and costly delay. It will also assure you the best in finished service work.

SI UNITS OF MEASURE

Because John Deere sells its products world-wide, U.S. units of measure are shown with their respective Metric equivalents throughout this technical manual. These equivalents are the SI (International System) Units of Measure.

**Thanks very much for your reading,
Want to get more information,
Please click here, Then get the complete
manual**

JustClickHere 

NOTE:

**If there is no response to click on the link above,
please download the PDF document first, and then
click on it.**

**Have any questions please write to me:
admin@servicemanualperfect.com**

SAFETY AND YOU



T27999N

INTRODUCTION

 This safety alert symbol identifies important safety messages in this manual and on the windrower. When you see this symbol, be alert to the possibility of personal injury and carefully read the message that follows.

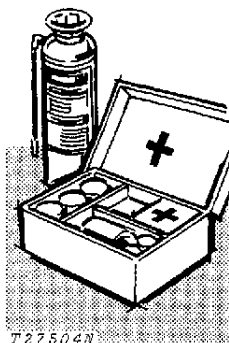

T27504N

Be prepared if an accident or fire should occur. Know where the first aid kit and the fire extinguishers are located—know how to use them.

SERVICE AREA

Keep the service area clean and dry. Wet or oily floors are slippery. Wet spots can be dangerous when working with electrical equipment.

Make sure the service area is adequately vented.

Periodically check the shop exhaust system for leakage. Engine exhaust gas is dangerous.

Be sure all electrical outlets and tools are properly grounded.

Use adequate light for the job at hand.

AVOID FIRE HAZARDS

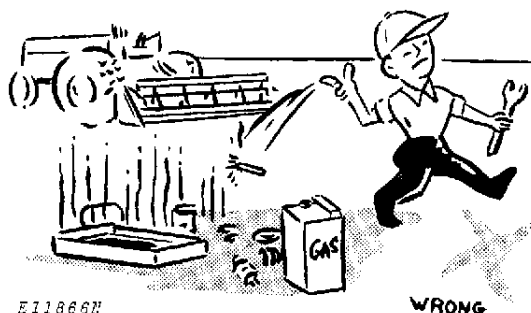

E11866N

WRONG

Don't smoke while refueling or handling highly flammable material.

Engine should be shut off when refueling.

Use care in refueling if the engine is hot.

Don't use open pans of gasoline or diesel fuel for cleaning parts. Good commercial, nonflammable solvents are preferred.

Provide adequate ventilation when charging batteries.

Don't check battery charge by placing metal objects across the posts.

Don't allow sparks or open flame near batteries.

Don't smoke near battery.

Never check fuel, battery electrolyte or coolant levels with an open flame.

Never use an open flame to look for leaks anywhere on the equipment.

Never use an open flame as a light anywhere on or around the equipment.

When preparing engine for storage, remember that inhibitor is volatile and therefore dangerous. Seal and tape openings after adding the inhibitor. Keep container tightly closed when not in use.

CLEANING THE WINDROWER

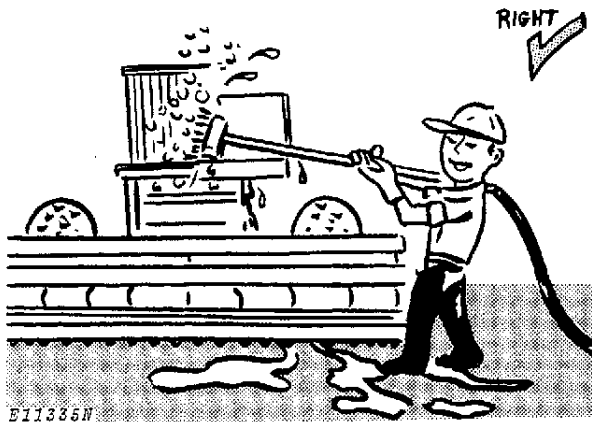

Always stop the engine before cleaning the windrower.

Keep the operator's platform clean. Do not use it as a storage area.

Keep the radiator screen free of foreign matter. Avoid a possible fire hazard.

Keep all equipment free of dirt and oil. In freezing weather, beware of snow and ice on ladder steps and operator's platform.

FLUIDS UNDER PRESSURE

Escaping fluid under pressure can have sufficient force to penetrate the skin, causing serious personal injury. Before disconnecting lines, be sure to relieve all pressure. Before applying pressure to the system, be sure all connections are tight and that lines, pipes and hoses are not damaged. Fluid escaping from a very small hole can be almost invisible. Use a piece of cardboard or wood, rather than hands, to search for suspected leaks.

If injured by escaping fluid, see a doctor at once. Serious infection or reaction can develop if proper medical treatment is not administered immediately.

Don't forget the hydraulic system or diesel fuel injection system may be pressurized! To relieve pressure, follow the instructions in this technical manual.

When checking hydraulic pressure, be sure to use the correct test gauge for the pressure in the particular system.

PERSONAL SAFETY

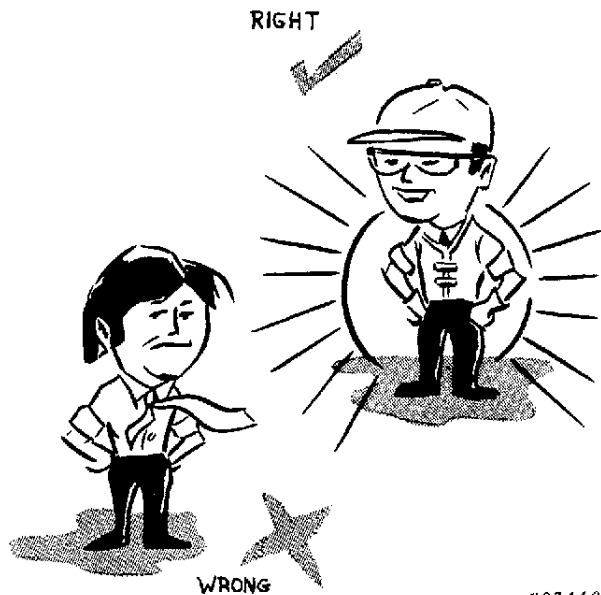

Always avoid loose clothing or any accessory—flopping cuffs, dangling neckties and scarves—that can catch in moving parts and put you out of work. Always wear your safety glasses while on the job.

Keep transmission and brake control units properly adjusted at all times. Before making adjustments, stop engine.

Before removing any housing covers, stop engine. Take all objects from your pockets which could fall into the opened housings. Don't let adjusting wrenches fall into opened housings.

Don't attempt to check belt tension while the engine is running.

Don't adjust the fuel system while the machine is in motion.

Before repairing the electrical system, or performing a major overhaul, make sure the batteries are disconnected.

Avoid working on equipment with the engine running. If it is necessary to make checks with the engine running, ALWAYS USE TWO PEOPLE—one, the operator, at the controls, the other checking the machine, always in view of the operator. Also, put the transmission in neutral, set the brake, and apply any safety locks provided. KEEP HANDS AWAY FROM MOVING PARTS.

Use extreme caution in removing radiator caps, drain plugs, grease fittings, or hydraulic pressure caps.

Section 10 GENERAL

CONTENTS OF THIS SECTION

	Page		Page
GROUP 5 - SPECIFICATIONS		GROUP 20 - LUBRICATION	
Specifications	5-1	General Information	20-1
		Lubricants	20-2
GROUP 10 - PREDELIVERY, DELIVERY, AND AFTER-SALE SERVICES		GROUP 25 - SEPARATION	
Predelivery Service	10-1	Operator's Cab.....	25-1
Delivery Service.....	10-4	Engine	25-3
After-Sale Inspection	10-4		
Torque Chart	10-7	GROUP 30 - SPECIAL TOOLS	
		Special Tools	30-1
GROUP 15 - TUNE-UP			
General Information	15-1		
Preliminary Engine Testing	15-1		
Engine Tune-Up	15-1		
Miscellaneous Testing	15-3		

Group 5 SPECIFICATIONS

TRACTION UNIT

Engine

Make	John Deere
Model	219
Number of cylinders	4
Type	4-stroke cycle, in-line, valve-in-head
Horsepower.....	70
Bore	4.02 in. (102 mm)
Stroke.....	4.33 in. (111 mm)
Piston displacement	219 cu. in. (3595 cm ³)
Compression ratio	16.3 to 1
Firing order	1-3-4-2
Recommended maximum speed (no load)	2665 rpm
Recommended idle speed	800 rpm
Fuel	Diesel
Cooling system	Pressurized
Lubrication system	Force-feed, pressurized with full-flow oil filter
Fuel system	Direct injection, inlet metering, distributing-type. Diaphragm-type fuel pump.

TRACTION UNIT—Continued

Electrical System

Starter, alternator, lights, and accessory voltage 12 volts

Propelling Drive Hydrostatic

Tire Sizes:

Drive wheels 18:4 x 16:1, 4-ply rated
(16 psi) (110 kPa)

Caster wheels 9:50 x 14, 4-ply rated
(16 psi) (110 kPa)

Torque

Front 140-170 ft-lbs (190-230 N·m)

Rear 85 ft-lbs (115 N·m) (11.5 kgm)

Ground Speed 0-12 mph (0-19 km/h)

Turning Radius Variable to 0 ft. (0 m)

Weight

(Without cab) (Approx.) 5,280 lbs. (2395 kg)

(With cab) (Approx.) 5,790 lbs. (2624 kg)

(With air-cond. cab) (Approx.) 6,150 lbs. (2790 kg)

Capacities

Fuel tank 37 U.S. gals. (151 l)

Hydraulic system 10 U.S. gals. (38 l)

Engine oil crankcase (including filter) 6 U.S. qts. (5.7 l)

Cooling system 14 U.S. qts. (13.2 l)

Main drive gear case 2-1/2 U.S. qts. (1.4 l)

Final drive gear case 9 U.S. qts. (8.5 l)

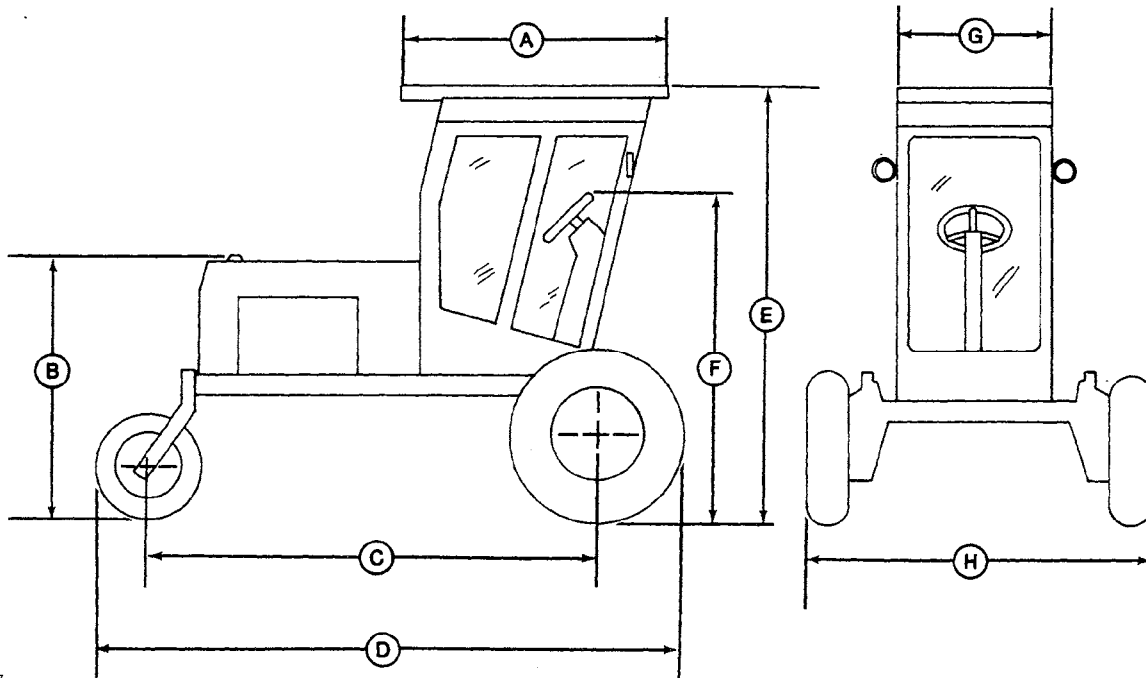

E14510N

E14510N

Fig. 1-Dimensions of 2280 Hydrostatic Drive Windrower

Windrower Dimensions

A—Length of cab	68 in. (1676 mm)
B—Height to top of radiator cap	82 in. (2083 mm)
C—Wheel base	123-5/8 in. (3140 mm)
D—Overall length	159-1/2 in. (4050 mm)
E—Height to top of cab	115-1/2 in. (2930 mm)
F—Height to top of steering wheel	93 in. (2360 mm)
G—Width of cab	44 in. (1118 mm)
H—Overall width	126 in. (3200 mm)

Group 10 PREDELIVERY, DELIVERY AND AFTER-SALES SERVICES

PREDELIVERY SERVICE

Because of the shipping factors involved, plus extra finishing touches that are necessary to promote customer satisfaction, proper delivery service is of prime importance to the dealer.

checks and services listed on the predelivery page, remove the page from the windrower operator's manual and file it with the shop order for the job. The page will certify that the windrower has received the proper predelivery service when that portion of the customer's John Deere Delivery Receipt is completed.

After completing the factory-recommended dealer

TEMPORARY WINDROWER STORAGE

Service	Specification	Reference
Check radiator for coolant loss and antifreeze protection.	2 inches (51 mm) above baffle.
Reduce shipping pressure of tires.	Page 10-5-2
Cover windrower and tires for protection and cleanliness.

BEFORE DELIVERING WINDROWER

COOLING SYSTEM

Inspect radiator for coolant loss.
Check antifreeze protection.

ELECTRICAL SYSTEM

Install electrolyte and charge batteries	FOS-20 Manual
Stamp date code on battery.	FOS-20 Manual
Connect alternator. Do not attempt to polarize.	Section 40
Clean terminals and connect battery cables.	Section 40

TIRES AND WHEELS

Adjust pressure of tires.	Operator's manual
Check front wheel cap screws and rear wheel hub bolts for tightness.	Front cap screws -
	140-170 ft-lbs (190-230 N·m)	
	Rear hub bolts -	
	85 ft-lbs (115 N·m) (12 kgm)	

BEFORE DELIVERING WINDROWER—Continued

Service	Specification	Reference
<i>LUBRICATION</i>		
Check crankcase oil level.	Section 10- Group 20
Check final drives oil level.	SAE 85-140 API GL5 Gear Lubricant	Operator's manual
Check hydraulic system oil level.	John Deere Hy-GARD Transmission and Hydraulic Oil	Operator's manual
Check main gear case oil level.	SAE 85-140 API GL5 Gear Lubricant	Operator's manual
Lubricate grease fittings.	John Deere Multi-Purpose Lubricant	Operator's manual
Lubricate drive chains.	SAE 30 or heavier engine oil	Operator's manual
<i>ENGINE</i>		
Remove protective covers from all engine openings.	
Fill fuel tank and start engine.	Operator's manual
Check operation of gauges and lights.
Check engine speeds.		
Slow idle	800 rpm
Fast idle	2665 rpm
<i>OPERATION</i>		
Check to be certain drive wheels Operator's manual are fully engaged or disengaged.	
Check master control operation.	Section 60- Group 10
Check hydrostatic drive operation.
Check all hydraulic system functions.	Section 70
Check parking brake operation.	Section 60- Group 10
Check steering operation.	Section 60 Group 05
Check seat operation.	Section 80- Group 15

Service	Specification	Reference
<i>GENERAL</i>		
Install non-slip cleats on operator's platform.	Operator's manual
All moving parts are working freely.
Install platform and harvesting units. Make sure platform lift arm lock plates are properly installed.	Operator's manual
Adjust platform float.	Operator's manual
Check tension of all belts and adjust if necessary.	Operator's manual
Check all chains for proper installation and adjustment.	Operator's manual
Check platform draper belt for cracks, missing rivets, etc.	Operator's manual
Check and, if necessary, lubricate all points of lubrication.	Operator's manual
Tighten accessible nuts and cap screws.
Clean windrower and touch up paint.

DELIVERY SERVICE

A thorough discussion of the operation and service of a new windrower at the time of delivery helps to assure complete customer satisfaction. Proper delivery should be an important phase of a dealer's program. A portion of the John Deere Delivery Receipt emphasizes the importance of proper delivery service.

Many complaints have arisen simply because the owner was not shown how to operate and service the new windrower properly. Enough time should be devoted, at the customer's convenience, to introducing the owner to the new windrower and explaining how to operate and service it.

The following procedure is recommended before the service technician and owner complete the delivery acknowledgments portion of the delivery receipt.

Using the windrower operator's manual as a guide, be sure that the owner understands these points thoroughly.

1. Controls and instruments.
2. How to start and stop the engine.
3. The importance of the break-in period.
4. All functions of the hydraulic system.
5. All functions of hydrostatic system.
6. Advise the customer of the optional harvesting units that are available for special crop and operating conditions.
7. The importance of lubrication and periodic services.
8. The importance of safety.

After explaining and demonstrating the above features, have the owner sign the delivery receipt and give the owner the operator's manual.

AFTER-SALE INSPECTION

The purchaser of a new John Deere windrower is entitled to a free inspection within the warranty period after the equipment has been "run in." The terms of this after-sale inspection are outlined on the back of the John Deere Delivery Receipt.

The purpose of this inspection is to make sure that the customer is receiving satisfactory performance from the windrower. At the same time, the inspection should reveal whether or not the windrower is being operated, lubricated, and serviced properly.

If the recommended after-sale service inspection is followed, the dealer can eliminate a needless volume of service work by preventing minor irregularities from developing into serious problems later on. This will promote strong dealer-customer relations and present the dealer an opportunity to answer questions that may have arisen during the first few days of operation. During the inspection service, the dealer has the further opportunity of promoting the possible sale of other new equipment.

The following inspection program is recommended within the first 100 hours of harvester operation.

Service	Specification	Reference
Cooling System		
Check radiator coolant level.		Operator's manual
Clean external surface of radiator core.
Check hoses and connections for leaks.



Service	Specification	Reference
Fuel System		
Remove water and foreign material from filter sediment bowls	Operator's manual
Bleed fuel system.	Operator's manual
Check fuel line and connections.
Electrical System		
Check specific gravity of battery (s).	Full charge - 1.260 at 80°F (26.7°C)	FOS-20 Manual
Check level of battery electrolyte.	To bottom of filler neck in cell.	Operator's manual
Check belt tension.	Alternator - 3/4-inch (19 mm) deflection with a 20 lb. (89 N) (8.9 kgm) force. Compressor - 1/4-inch (6.4 mm) deflection with a 15 lb. (67 N) (6.7 kgm) force.	Operator's manual
Start engine and check operation of starter, lights, and indicator lamps.	Operator's manual
Tires and Wheels		
Adjust pressure of tires.	Operator's manual
Check front wheel cap screws and rear wheel hub bolts for tightness.	Front cap screws - 140-170 ft-lbs (190-230 N·m) Rear hub bolts - 85 ft-lbs (115 N·m) (12 kgm)
Lubrication		
Check crankcase oil level.	To upper mark on dip stick.	Operator's manual
Check hydraulic system oil level.	To upper mark on dip stick.	Section 10 - Group 20
Check hydraulic lines and connections.
Check final drive gear case oil level.	To check plug.	Section 10 - Group 20
Check main drive case oil level.	To check plug.	Section 10 - Group 20
Check cutterbar drive case.	To check plug.	Section 10 - Group 20
Lubricate grease fittings.	Operator's Manual

AFTER-SALE INSPECTION—Continued

Service	Specification	Reference
Engine		
Check air cleaner.	Operator's manual
Check fan belt tension.	3/4 -inch (19 mm) deflection with 20 lb (89 N) (8.9 kgm) force	Operator's manual
Check valve clearance (static).	Intake: 0.014-in. (0.356 mm) Exhaust: 0.018-in. (0.457 mm)	Section 20 - Group 10
Check engine speed.		
Slow idle	800 rpm.
Fast idle	2665 rpm
Check operation of starter, alternator, gauges, and indicator lights.	Operator's manual
Operation		
Check platform drive clutch lever adjustment.	Operator's manual
Check parking brake adjustment.	Operator's manual
Check hydraulic system operation.	Section 70
Check hydrostatic system operation.	Section 70
Check steering.	Section 60
Check headlight adjustment.	Section 40
Check cab controls and seat operation.	Operator's manual
Check drive chain adjustments.	Operator's manual
Check V-belt adjustments.	Operator's manual

Service	Specification	Reference
General		
Tighten accessible nuts and cap screws
Visual inspection.
All safety shields in place.
Clean windrower and touch up paint.

TORQUE CHART

RECOMMENDED TORQUE IN FT-LBS (Nm) COARSE AND FINE THREADS			
  			
Bolt Diameter	Plain Head	Three Dashes	Six Dashes
1/4	Not used	10 (14)	14 (19)
5/16	Not used	20 (27)	30 (41)
3/8	Not used	35 (47)	50 (68)
7/16	35 (47)	55 (75)	80 (108)
1/2	55 (75)	85 (115)	120 (163)
9/16	75 (102)	130 (176)	175 (237)
5/8	105 (142)	170 (230)	240 (325)
3/4	185 (251)	300 (407)	425 (576)
7/8	160 (217)	445 (603)	685 (929)
1	250 (339)	670 (908)	1030 (1397)
1-1/8	330 (447)	910 (1234)	1460 (1980)
1-1/4	480 (651)	1250 (1695)	2060 (2793)

E11579N

The types of bolts and cap screws are identified by head markings as follows:

Plain Head: regular machine bolts and cap screws.

3-Dash Head: tempered steel high-strength bolts and cap screws.

6-Dash Head: tempered steel extra high-strength bolts and cap screws.

Machine bolts and cap screws 7/8-inch and larger are sometimes formed hot rather than cold, which accounts for the lower torque.

